

...for best
measuring results

PWB+

TOOL MASTER BASIC



The cost-effective **ENTRY SOLUTION** which is covering
all required customer needs for measuring tools and materials.

- precise
- reliable
- sustainable

evoset

THE PERFECT MATCH



Why PWB - because of today's growing demand on quality, optimised production process and flexibility!

- Excellent quality-price ratio
- Measuring in high quality
- Manufactured with branded components
- Intuitive software and ergonomic hardware
- Economical
- Worldwide online-support
- Quality "Made in Switzerland"

Evoset is an international acting company in the field of tool presetting and measuring.

We combine professional productivity with ultimate user-friendliness and tailor made solutions.

The products focus is on optimised implementation of individual customer needs. Evoset AG offers intelligent and complementary solutions with a great price-performance ratio. This allows companies to improve the utilisation of their capital-intensive CNC machines and to increase their productivity up to 25% per unit.

As a production industry partner, Evoset AG continually develops new devices and systems in order to further optimise industrial processes.

In-house developments of measuring units, software, assembly and an engineering staff ensure required know-how and success for your investments.

PROFESSIONAL EQUIPMENT

TECHNICAL DATA

Type	Pneumatic clamping, practical design and ease of use
Measuring range Standard.(\varnothing mm / L mm)	400 / 40 400
Axis fixation	Pneumatics
Fine adjustment	Handwheel per axis
Tool mounting	Needle bearing
Measuring procedure	Image processing with EyeRay® Hawk

YOUR BENEFITS

- Image processing with EyeRay® Hawk software
- Infinite fine adjustment in X- and Z-axes
- Quick focusing of tool cutting edge
- CMOS digital camera with tele centric lens
- High concentricity due to needle bearing
- High measuring repeatability
- Plug-in Desktop Solution with 20" screen, mouse
- With integral ISO50 or ISO40 spindles
- Sturdy cast iron base

PROFESSIONAL EQUIPMENT



MASTER MANDRIL
SK40 / SK50 : \varnothing 30 x 90

SOFTWARE

EyeRay® SOFTWARE FOR PRACTICAL APPLICATION

All **FUNCTIONS** of the software can be operated through only six basic icons. The operator works in a single screen and handles the system after a short training safely and quickly using all functions. Favourite fields can be created individually by the user.

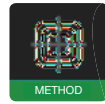

MEASURING METHODS

Hawk

Maximum method	X
Presetting method	X
Total image method	X
Multi-cutting edge method	X
Incident light method with single LED	X
Incident light method with ring light	O
Fixed-axis method	X
Centre method	X
Preset theoretical angle and radius	X
Point measurement	X
Centre height measurement with camera CHC	O



MEASURING FUNCTIONS

Basic measuring functions	X
Advanced measuring functions	-
User-created measuring functions	-
Measuring window	X
Special measuring functions	O

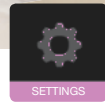

SETTINGS

Multi-lingual / individual adjustable	X
Illumination setting	X
Camera parallelism	X
Pixel size	X
Axis parallelism	X
Absolute zero	X
Parameters	X

PRINT

Label print format 1	X
Label print format 2	-
Print tool list	X
Print measuring report	-



DATABASE

Reference point management	X
Basic tool management	-
Full tool management	-
Backup and restore	X

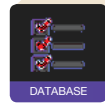

DATA TRANSFER

Tool list create / print	X
Tool list open / save	-
Data output to file (post-processor)	O
Data output to a storage medium (e.g. Baluff)	O
Export to Excel	-

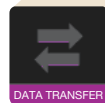

„X” → Standard „O” → Optional „-” → Not available

ACCESSORIES

SK

- Reduction SK/ISO to SK/ISO
In-house calibration ensures consistent quality
- Offset value is engraved on the reduction according to the following table

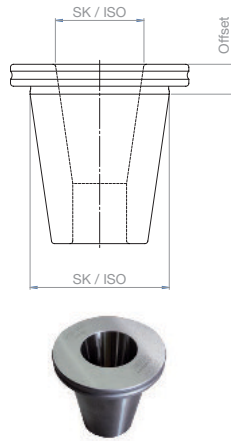

Internal shape	Offset value (Z)	
	External shape	
	SK50 / ISO50	SK40 / ISO40
SK10	30 mm	30 mm
SK15	30 mm	30 mm
SK20	15 mm	15 mm
SK25	15 mm	15 mm
SK30	15 mm	15 mm
SK35	15 mm	15 mm
SK40	15 mm	-
SK45	15 mm	-

HSK (shapes A to F)

- Reduction SK/ISO to HSK, available with and without clamping attachment
- Offset value is engraved on the reduction according to the following table

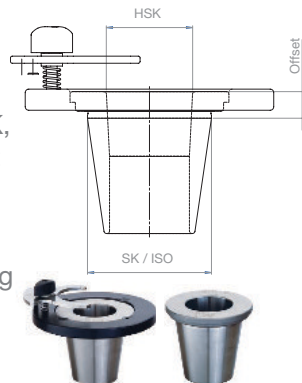

Internal shape	Offset value (Z)	
	External shape	
	SK50 / ISO50	SK40 / ISO40
HSK-A25	15 mm	15 mm
HSK-A32	15 mm	15 mm
HSK-A40	15 mm	15 mm
HSK-A50	15 mm	15 mm
HSK-A63	15 mm	60 mm
HSK-A80	52 mm	-
HSK-A100	70 mm	-

VDI with clamp lever

- Clamping of the VDI tool holder with clamping lever
- Clearance provided in the reduction for O-ring of the VDI shank

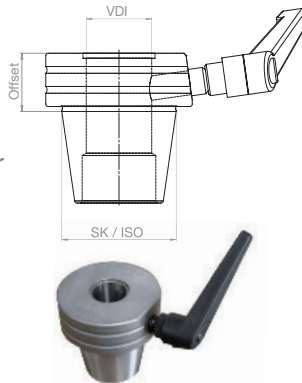

Internal shape	Offset value (Z)	
	External shape	
	SK50 / ISO50	SK40 / ISO40
VDI16	50 mm	50 mm
VDI20	35 mm	35 mm
VDI25	35 mm	35 mm
VDI30	35 mm	35 mm
VDI40	35 mm	70 mm
VDI50	35 mm	90 mm
VDI60	100 mm	-

VDI with index

- 4x90° indexing on reduction. VDI tool holder is aligned in reduction by means of centring pins
- Clearance provided in reduction for O-ring of the VDI shank

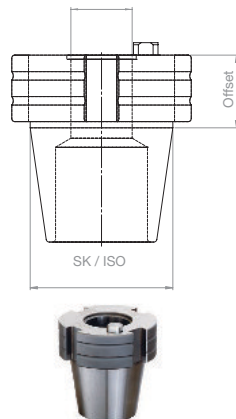

Internal shape	Offset value (Z)	
	External shape	
	SK50 / ISO50	SK40 / ISO40
VDI16	50 mm	50 mm
VDI20	35 mm	35 mm
VDI25	35 mm	35 mm
VDI30	35 mm	35 mm
VDI40	35 mm	80 mm
VDI50	35 mm	-
VDI60	100 mm	-
VDI80	140 mm	-

Capto ,easy'

- Capto tool holder is centred using the 3 highest points of the polygon in the reduction, fixed with clamping claw

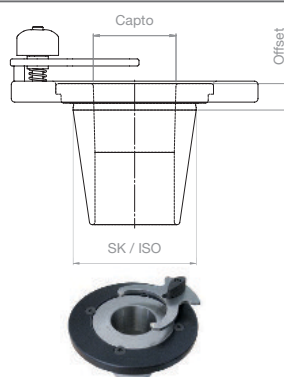

Internal shape	Offset value (Z)	
	External shape	
	SK50 / ISO50	SK40 / ISO40
C3	15 mm	-
C4	15 mm	-
C5	15 mm	-
C6	15 mm	-
C8	52 mm	-
C10	80 mm	-

PWB NEEDLE BEARINGS

FOR HIGHEST REPEATABILITY

- Protection against damage of the ground cone
- Lower surface pressure than ball-bearings, thus less wear
- Higher centring forces than when using surface contact
- Oil and dirt remain in the cavities and have no influence on the measuring accuracy
- Integrated edge protection when changing tools
- Easy to clean
- No maintenance costs

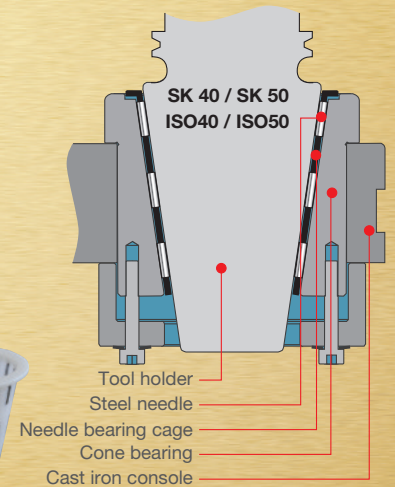





PAT EP0498232

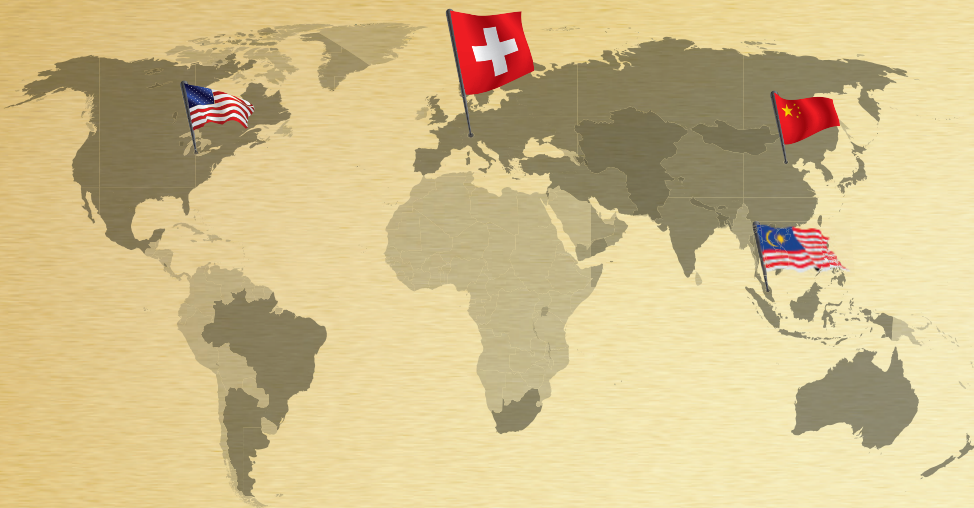

ONE SOURCE SOLUTION

THE SERVICE LEVEL YOU NEED



-  Steg / Zurich
Headquarter and production facility
-  Service & technical office
-  Service & technical office
-  Service & technical office

In addition to our strong product development, planning and production, we offer our customers an experienced and professional worldwide service.

Our high qualified technical team will accompany you from planning to commissioning.

Thanks to our online-maintenance, we guarantee expert problem diagnosis, fast spare parts delivery of all repairs and maintenance issues.

evoset

Evoset AG
Besche Mattenstrasse 1
3940 Steg | Switzerland
Schwättenmos 6
8126 Zumikon | Switzerland
Fon +41 27 922 04 50
info@evoset.com
www.evoset.com

Distributor

